

GEORGE P. BEACH
SUPERINTENDENT



MAJOR JOSEPH A. TRIPODO
TROOP COMMANDER

**STATE OF NEW YORK
NEW YORK STATE POLICE
TROOP "F" HEADQUARTERS
55 CRYSTAL RUN ROAD
MIDDLETOWN, NY 10941
(845) 344-5300**

January 9, 2017

Trooper Joseph P. Santopietro
New York State Police
Middletown, New York

LETTER OF CENSURE

Dear Trooper Santopietro:

On August 19, 2016, you were operating your assigned Division vehicle when you were involved in a troop car accident. This accident has been reviewed at Troop Headquarters and it was determined to have been preventable on your part. On January 9, 2017 you appeared before me, executed a waiver, and requested that I adjudicate the disciplinary action.

This accident occurred while you were driving westbound on Interstate 84 and attempting to enter the Exit ramp at 3E. As a result of traveling at an unsafe speed, you were unable to negotiate the curved segment of the ramp and in doing so, you lost control of the troop car and drove off the paved portion of the west shoulder. Upon leaving the roadway, your vehicle struck a highway delineator and then drove down an embankment where it subsequently incurred undercarriage damage. Although there were no injuries associated with this accident, as a professional driver, you are expected to drive more carefully.

It is my decision that you receive a letter of censure for your actions. I trust that you will accept this censure in the spirit that it is given and that you will drive more cautiously in the future.

Sincerely,

Major Joseph A. Tripodo
Troop Commander
Troop F

NEW YORK STATE POLICE

MEMORANDUM

TROOP F STATION Middletown

DATE December 21, 2016

TO: Deputy Superintendent Stephen J. Smith, Field Commander
Attn: Major, Division Traffic

FROM: Major Joseph A. Tripodo, Troop Commander

**SUBJECT: TROOP CAR ACCIDENT – 08/19/16
TROOPER JOSEPH P. SANTOPIETRO**

Reference is made to the attached self-explanatory investigative report regarding the above subject.

I have reviewed this accident and it is my opinion that it was preventable.

Member has consented to adjudication by the Troop Commander under the provisions of Article 3, Disciplinary Action, Rules of the New York State Police. Results of the adjudication will be forwarded to you upon completion of same.

Attach.

NEW YORK STATE POLICE

MEMORANDUM

TROOP F STATION Middletown

DATE December 21, 2016

TO: Major Joseph A. Tripodo, Troop Commander

FROM: T/Sergeant Scott Mohl, Troop Traffic Supervisor *SCM*

**SUBJECT: TROOP CAR ACCIDENT – 08/19/16
TROOPER JOSEPH P. SANTOPIETRO**

Reference is made to the attached self-explanatory investigative report regarding the above subject.

I have reviewed this accident and it is my opinion that it was preventable.

The primary cause of this accident was unsafe speed.

Attach.

NEW YORK STATE POLICE

MEMORANDUM

Troop F Station Headquarters

Date December 20, 2016

To: Major Joseph A. Tripodo, Troop Commander, Troop F

From: Sergeant William J. Meyers *WJM*

Subject: **DIVISION VEHICLE PDAA – F106**
TROOPER JOSEPH P. SANTOPIETRO – EOD 06/28/04

Reference is made to Administrative Message Report AMSSM21360JJ7B, dated August 19, 2016, and the attached investigative report of Sergeant WILLIAM J. MEYERS

On August 19, 2016, at approximately 2:45PM, Trooper JOSEPH P. SANTOPIETRO was operating Division vehicle F106. As Trooper SANTOPIETRO was exiting Interstate 84 at Exit 3E he failed to negotiate the curved portion of the ramp and drove off the west shoulder and down an embankment. Division Vehicle F106 and a highway delineator were damaged. Trooper SANTOPIETRO was not injured as a result of the collision.

Investigation into this matter has determined the culpability for the collision lies solely with Trooper SANTOPIETRO and could only have been prevented by him. Trooper SANTOPIETRO's inattention and failure to keep right caused this collision. It is recommended that the collision be classified as preventable.

NEW YORK STATE POLICE**MEMORANDUM**Troop F Station SP MiddletownDate August 19th, 2016**To: Major Joseph A. Tripodo, troop Commander, troop F****From: Trooper Joseph P. Santopietro****Subject: DIVISION VEHICLE PROPERTY DAMAGE ACCIDENT - F106**

Member is constructing this Memorandum as ordered by T/Sergeant WILLIAM J. MEYERS in regards to **DIVISION VEHICLE PROPERTY DAMAGE ACCIDENT - F106** to which Member was driving on August 19th, 2016. I have been advised of my rights to representation pursuant to Article 16.2 of the contract and provide the following account.

Member was operating marked division vehicle F106 at approximately 2:45pm, on August 19th, 2016 and failed to negotiate turn at exit 3E on I84, in Town of Wawayanda, Orange County New York. Member attempted to correct vehicle and subsequently failed, leaving the roadway onto grassy shoulder and down embankment. Member was uninjured from accident.

U F	2 STATION SP MIDDLETOWN	2A T2S F044	NEW YORK STATE POLICE INVESTIGATION REPORT				B C I	3 STATION	3A T2S		
	4 CASE NO. 7086625	1 TROOP _____ F				5 CASE NO.					
C O M P L A I N T	C-1	6 COMPLAINANT LAST NAME				7 DOB					
	8 ADDRESS						9 PHONE				
	10 EMPLOYER				10A OCCUPATION		10B BUS. PHONE				
	11 PLACE OF OCCURRENCE - SPECIFIC LOCATION EXIT 3E DECELERATION RAMP FROM W/B I-84						11A COUNTY ORANGE				
	11B C-T-V T/WAWAYANDA		11C C-T-V CODE F3668		12 DATE OCCURRED 08/19/16	TIME OCCURRED 2:45PM	13 DATE REPORTED 08/19/16	TIME REPORTED 2:47PM			
14 OWNER IF OTHER THAN COMPLAINANT						15 WEATHER		<input checked="" type="checkbox"/> CLEAR <input type="checkbox"/> RAIN <input type="checkbox"/> SLEET <input type="checkbox"/> CLOUDY <input type="checkbox"/> FOG <input type="checkbox"/> SNOW			
C A S E D A T A	18 CHARACTER OF CASE DIVISION VEHICLE AA - 1 VEHICLE PROPERTY DAMAGE						17 COUNTS 1	18 CASE NO. 7086625	19 C.C. CODE MVE5058		
	20 CODE: STOLEN (S) / USED IN CRIME (C) CRIM. MISCH (M) / RECOVERED (R) EVIDENCE (E) / GENL. 2 (A) TERM. MSG. (T) / OTHER (O)						21 MONETARY VALUE				
	P-1	CODE	QTY	DESCRIPTION				ID - SERIAL NUMBER			
V E H	V-1	<input type="checkbox"/> USED IN CRIME <input checked="" type="checkbox"/> ACC MV <input type="checkbox"/> ACC NON -MV <input type="checkbox"/> SUSPECT <input type="checkbox"/> CRIM. MISCH <input type="checkbox"/> STOLEN <input type="checkbox"/> RECOVERED <input type="checkbox"/> OTHER (O)		DESCRIPTION - MAKE AUTO/ VAN 140554 MLG 25532					YR MFG 14	REG. NO. F106	STATE NY
	W-1	<input type="checkbox"/> USED IN CRIME <input type="checkbox"/> LAWFUL SURRENDER <input type="checkbox"/> UNLAWFUL POSS. <input type="checkbox"/> STOLEN <input type="checkbox"/> OTHER		COLOR BL/GLD		BODY - MODEL CHARGER		VIN - ID NO 2C3CDXKT1EH356790		<input type="checkbox"/> YES <input type="checkbox"/> NO <input type="checkbox"/> YES <input type="checkbox"/> NO	
W E A P O N	<input type="checkbox"/> REVOLVER <input type="checkbox"/> PISTOL <input type="checkbox"/> RIFLE <input type="checkbox"/> SHOTGUN <input type="checkbox"/> OTHER <input type="checkbox"/> OTHER										
	MAKE - TYPE MODEL			CAL - GA		NAME OF OWNER OR LICENSEE					
	SERIAL NO.			<input type="checkbox"/> UNLOADED <input type="checkbox"/> LOADED		ADDRESS					
	FINISH			TOT. CAPACITY		LICENSE NO.		DATE ISSUED			
D O C U M E N T	D-1	KIND OF DOCUMENT			NAME OF RECEIVER			REASON <input type="checkbox"/> NO ACCT <input type="checkbox"/> ACCT CLSD <input type="checkbox"/> INSUFF FUNDS <input type="checkbox"/> FORGERY			
	NAME OF MAKER - ID OR ADDRESS GIVEN						<input type="checkbox"/> YES <input type="checkbox"/> NO <input type="checkbox"/> YES <input type="checkbox"/> NO				
	BANK DRAWN ON - ADDRESS						DOC. NO.				
	DOCUMENT DATE		DOCUMENT AMOUNT		MONEY PROPERTY OR SERVICE OBTAINED		<input type="checkbox"/> YES <input type="checkbox"/> NO				
D A M	25 DESCRIBE OR LIST PHYSICAL DAMAGE OR ANY OTHER LOSS FRONT AND REAR END DAMAGE							27 TOTAL VALUE 7,849.66			
D I S P O	INSUR	PROPERTY INSURED? <input checked="" type="checkbox"/> YES <input type="checkbox"/> NO		NAME OF INSURER SELF INSURED / STATE OF NEW YORK				AMOUNT OF INSURANCE FULL		27 TOTAL VALUE 7,849.66	
	V-1	DATE 08 19 16	DESCRIPTION TOWED BY ADAMIS TO TROOP F HEADQUARTERS							RETENTION DESTROY	
W I T N E S S	WT-1	NAME (LAST, FIRST MIDDLE) - ADDRESS					AGE	DOB			
								30A 11 30 16			
REPORT DATE											

16038547

NEW YORK STATE POLICE INVESTIGATION REPORT

NATURAL DEATH (ND)
ACCIDENT VICTIM (AV)
OTHER (O)

31	CODE	ASSAULT (A) HOMICIDE (H) SUICIDE (S) ATTEMPTED SUICIDE (AS)	NAME (LAST, FIRST MIDDLE)	ADDRESS	SEX	AGE	DOB	
V I C T I M	NATURE OF INJURIES				HOSPITAL AND/OR PHYSICIAN			
	DATE OF DEATH	CORONER OR MEDICAL EXAMINER			AUTOPSY YES <input type="checkbox"/> NO <input type="checkbox"/>		PATHOLOGIST	
	KIN NOTIFIED YES <input type="checkbox"/> NO <input type="checkbox"/>							
32	CODE	UNKNOWN SUBJECT (U) CRIM. SUM. (C)	PERPETRATOR (P) ACCOMPLICE (A)	DEFENDANT (D) SUSPECT (S)	WANTED-WARRANT (W) JUVENILE (J)	OTHER (O)	DRIVER	
T I T L E	T-1	CODE	NAME (LAST, FIRST MIDDLE)		ADDRESS - ALIAS		SEX	
	T-2	O	SANTOPIETRO, JOSEPH P.		EOD 06/28/04 SP MIDDLETOWN - TIM		M	
	T-3							
	T-4							
	T-5							
	T-6							
	T-7							
	T-8							
W A N T E D	TITLE NO.	RACE	HT	WT	HAIR	EYES	CRIME	
	JUDGE - NAME ADDRESS AND TITLE						COUNTY	SECTION
	DATE ISSUED						EXTRADITE YES <input type="checkbox"/> NO <input type="checkbox"/>	
N Y S P I N	INQUIRY	DCJS	MESSAGES	NO.	FILE	DATE	STATION	
	NO	YES	NO					
	YES	NO	YES					
S O L F A C T O R S	THE PRESENCE OR ABSENCE OF ANY INDIVIDUAL FACTOR IS INDICATED BY A "YES" OR "NO"							
	YES <input type="checkbox"/> NO <input type="checkbox"/>	WITNESS TO CRIME			YES <input type="checkbox"/> NO <input type="checkbox"/>	PROPERTY TRACEABLE/IDENTIFIABLE		
	YES <input type="checkbox"/> NO <input type="checkbox"/>	IDENTIFICATION/DESCRIPTION OF SUSPECT/VEHICLE			YES <input type="checkbox"/> NO <input type="checkbox"/>	DISTINCTIVE/SIGNIFICANT MO		
E N C L O S U R E S	E-1 GENL 7 OF TPR. SANTOPIETRO							
	E-2 GENL 34D							
	E-3 PHOTO CONTACT SHEET							
	E-4 COPY OF AMS MESSAGE AMSM21360JJ7B							
	E-5 MV104A							
	E-6 MV104L							
	E-7 ESTIMATE OF REPAIRS							
S U M	COMPLAINANTS	PROPERTIES	VEHICLES	WEAPONS	DOCUMENTS	WITNESSES	VICTIMS	
	0	0	1	0	0	0	0	
TITLES		WANTEDS						
1		0						
SIGNATURE AND RANK <i>William M. Rogers - Sgt.</i>				SHIELD NO. 2028	SIGNATURE AND RANK		SHIELD NO.	
STATION SP MIDDLETOWN				CASE NO. 7096625	STATION		CASE NO.	
APPROVED				APPROVED				

NEW YORK STATE POLICE

CONTINUATION SHEET

TROOP F	STATION SP MIDDLETOWN
------------	--------------------------

COMPLAINANT - LAST NAME, FIRST, MIDDLE

CASE NO. SJS 7086625

1. On 08/19/16, at approximately 2:47PM, I was contacted by (T-1) Trooper JOSEPH P. SANTOPIETRO (EOD 06/28/04) Troop F TIM , who advised that he had just run off the the Exit 3E deceleration ramp as he was exiting from Interstate 84 west bound in Division vehicle F106. I contacted Major Joseph A. Tripodo who assigned me to investigate.
2. On 08/19/16, the scene is described as follows, the Interstate 84 Exit 3E ramp has a straight deceleration section the progresses into a curve and ends where it meets State Route 17M. The roadway is paved. I observed (V-1) Divison vehicle F106 off the west shoulder and down an embankment. There was damage to the front and rear of the vehicle and a road delineator had been struck. The damage was consistant with driving off the roadway and striking a delineator.
3. On 08/19/16, Trooper SANTOPIETRO (T-1) was interviewed and stated he failed to negotiate the curve and drove Division vehicle F106 off the west shoulder of the ramp and down the embankment. Trooper SANTOPIETRO (T-1) states he was not injured as a result of the collision. Trooper SANTOPIETRO was directed to submit a memorandum, attached as Enclosure #1.
4. On 08/19/16, Sergeant MARK A. PRESTIGIACOMO photograhed the scene and the damage to Division vehicle F106 (V-1). Genl 34D and photocontact sheet are attached as Enclosures #2 and #3 respectively..
5. On 08/19/16, Administrative Message # AMSM21360JJ7B was completed. A copy of the Administrative Message is attached as Enclosure #4.
6. On 08/20/16, Sergeant MARK A. PRESTIGIACOMO completed an MV104A - Police Accident Report and a MV104L - Report of Motor Vehicle Accident Police Line of Duty Accident. Copies are attached as Enclosures #5 and #6 respectively.
7. On 8/2616, at the direction of DONALD E. WIEBOLDT, Troop F MEMS II, an estimate of repairs in the amount of \$7,849.66 was prepared by T&C Auto Body, ST 17M, Middletown, NY. A copy of the estimate is attached as Enclosure #7.
8. Closed by Investigation.

RCI



Administrative Message Report

Print\Run Date 08/19/2016

AMS # AMSM21360JJ7B

Date\Time Reported\Discovered 08/19/2016 14:45	Agency ORI NYSP MIDDLETOWN	TZS F044
--	--------------------------------------	--------------------

Message
DIVISION VEHICLE - PDAA

Investigated By T/SGT. WILLIAM J. MEYERS, SGT. MARK A. PRESTIGIACOMO	Units Responded UF	Photos YES	Videotape NO
--	------------------------------	-------------------	---------------------

Narrative

On this date at approximately 2:45 p.m., Trooper JOSEPH P. SANTOPIETRO, Troop F TIM detail, operating F106, a 2014 Dodge Charger, was exiting Interstate 84 westbound at Exit 3E in the Town of Wawayanda when he failed to negotiate a curve on the off ramp. F106 exited the roadway off the west shoulder of the ramp, struck a delineator and continued down a small embankment. No injuries reported.

Major Joseph A. Tripodo advised by T/Sgt. William J. Meyers.

# Vehicles 1	# Injured 0	# Deceased 0	Apparent Cause PENDING INVESTIGATION
------------------------	-----------------------	------------------------	--

County ORANGE	C/TV Name WAWAYANDA, TOWN OF - 3668	Location\ Street Name \ Mile Post Marker INTERSTATE 84 W/B EXIT 3E OFF RAMP
-------------------------	---	---

Weather Conditions 1 - CLEAR	Road Conditions 1 - DRY
--	-----------------------------------

Description of Damage
FRONT AND REAR DAMAGE

Criminal Action

Sent Date \ Sent Time 08/19/2016 19:49	Sent By PRESTIGIACOMO MARK	Authorized By MAJOR JOSEPH A. TRIPODO
--	--------------------------------------	---

Notification TROOP

Driver Information 1

Driver Name SANTOPIETRO, JOSEPH P	DOB [REDACTED]	Gender M	License State	Chemical Test NO	Driver Charged NO
---	--------------------------	--------------------	----------------------	-------------------------	--------------------------

Address 1220 WASHINGTON AVE	City ALBANY	State NY	Zip 12226
---------------------------------------	-----------------------	--------------------	---------------------

Violations

Driver Member? YES	Member Rank TROOPER	Date of Entry 06/28/2004	Member Shield 5241	Member Shift B
------------------------------	-------------------------------	------------------------------------	------------------------------	--------------------------

Owner Information 1

Name (exactly as printed on registration)
NYSP,

Address 1220 WASHINGTON AVE	City ALBANY	State NY	Zip 12226
---------------------------------------	-----------------------	--------------------	---------------------

Insurance Company and Code 994 - GOVERNMENT OWNED

Vehicle Information 1

License Plate # POLICE	State NY	Vehicle Year 2014	Make DODG	VIN # 2C3CDXKT1EH356790
----------------------------------	--------------------	-----------------------------	---------------------	-----------------------------------

Van # 140554	Mileage 25532
------------------------	-------------------------

School Bus	NO	Front Airbags Deployed	NO
Comm. Veh.	NO	Side Airbags Deployed	NO
NYSP Veh.	YES	Fire Suppression Deployed	NO

Equipment Damage	NO	Equipment Damage Description	
-------------------------	----	-------------------------------------	--

POLICE ACCIDENT REPORT

MV-104A (6/04)

Local Codes 7086625 SP2F1260JG99

AMENDED REPORT

Accident Date: Month 8, Day 19, Year 2016. Day of Week: FRIDAY. Military Time: 14:45. No. of Vehicles: 1. No. Injured: 0. No. Killed: 0. Not Investigated at Scene: [] Left Scene: [] Police Photos: [X] Yes [] No. Accident Reconstructed: []

VEHICLE 1. VEHICLE 1 - Driver License ID Number [redacted]. State of Lic. NY. Driver Name - exactly as printed on license: SANTOPIETRO, JOSEPH P. Address (Include Number and Street): 1220 WASHINGTON AVE. Apt. No. [redacted].

City or Town: ALBANY. State: NY. Zip Code: 12226. Date of Birth: [redacted]. Sex: M. Unlicensed: []. No. of Occupants: 01. Public Property Damaged: [X].

Name - exactly as printed on registration: NYS POLICE. Sex: [redacted]. Date of Birth: [redacted]. Address (Include Number and Street): 1220 WASH AVE BLDG 22. Apt. No. [redacted]. Haz. Mat. Code: [redacted]. Released: [].

City or Town: ALBANY. State: NY. Zip Code: 12226.

Plate Number: POLICE. State of Reg. NY. Vehicle Year & Make: 2014 DODG. Vehicle Type: POLI. Ins. Code: 994.

Violation Section(s): [redacted]

Check if involved vehicle is: more than 95 inches wide; more than 34 feet long; operated with an overweight permit; operated with an overdimension permit. VEHICLE 1 DAMAGE CODES: Box 1 - Point of Impact: 2, 1, 8. Box 2 - Most Damage: 2, 3, 7, 4, 9. Vehicle By: ADAMIS. Towed To: SP MIDDLETOWN. VEHICLE DAMAGE CODING: 1-13 SEE DIAGRAM ON RIGHT. 14. UNDERCARRIAGE 17. DEMOLISHED 15. TRAILER 18. NO DAMAGE 16. OVERTURNED 19. OTHER

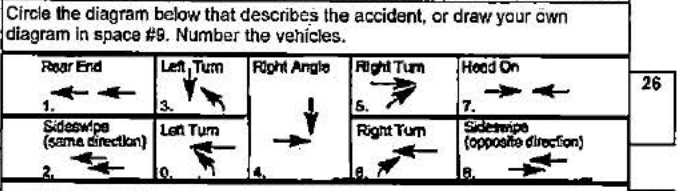
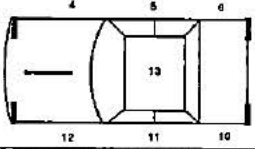

ACCIDENT DIAGRAM. See the last page of the MV-104A for the accident diagram. Cost of repairs to any one vehicle will be more than \$1000. [] Unknown/Unable to determine [X] Yes [] No

Reference Marker: 8 4 I. Coordinates (if available): Latitude/Northing: 4589035. Longitude/Easting: 553163. Place Where Accident Occurred: County ORANGE. City [] Village [] Town of WAWAYANDA. Road on which accident occurred: I 84 W/B EXIT 3E OFF RAMP. at 1) intersecting street: I 84 W/B. or 2) [] N [] S of [] E [] W (Milepost, Nearest intersecting Route Number or Street Name)

Accident Description/Officer's notes: V-1 was exiting Interstate 84 westbound at Exit 3E when OP V-1 failed to negotiate a curve on the off ramp. V-1 exited the roadway off the west shoulder of the off ramp, struck a delineator and continued down a small grass embankment. PROPERTY DAMAGED BY VEHICLE #01- DELINEATOR NYS DOT 3233 US-6 MIDDLETOWN, NY 10940

Table with columns: 8, 9, 10, 11, 12, 13, 14, 15, 16, 17 BY, TO 18, Names of all Involved, Date of Death Only. Row A: 1, 1, 4, 1, [redacted], M, -, -, -. Name: SANTOPIETRO, JOSEPH.

Officer's Rank and Signature: SGT [Signature]. Print Name In Full: MARK A PRESTIGIACOMO. Badge/ID No.: 5022. NCIC No.: 13502. Precinct/Post Troop/Zone: F2. Station/Beat Sector: 11. Reviewing Officer: MOHL, SCOTT. Date/Time Reviewed: 8/26/2016 12:45.

Local Codes
7086625
SP2F1260JG99

POLICE ACCIDENT REPORT

MV-104A (6/04)

AMENDED REPORT

Accident Date			Day of Week	Military Time	No. of Vehicles	No. Injured	No. Killed	Not Investigated at Scene	Left Scene	Police Photos
Month	Day	Year								
8	19	2016	FRIDAY	14:45	1	0	0	<input type="checkbox"/>	<input type="checkbox"/>	<input checked="" type="checkbox"/> Yes <input type="checkbox"/> No
								Accident Reconstructed	<input type="checkbox"/>	

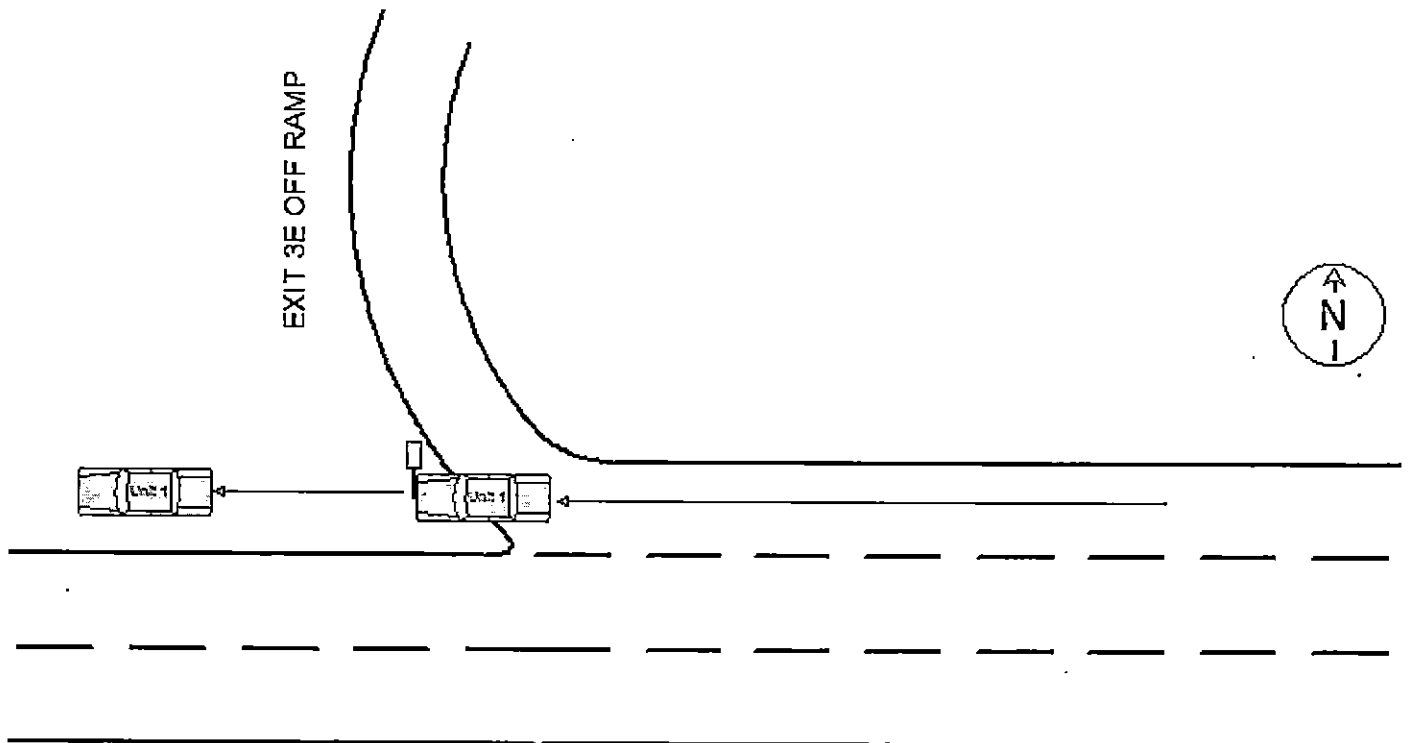

INTERSTATE 84 W/B
T/WAWAYANDA

(NOT TO SCALE)

New York State Department of Motor Vehicles
REPORT OF MOTOR VEHICLE ACCIDENT
POLICE LINE OF DUTY ACCIDENT

AMENDED REPORT

Page 1 of 1 Pages

Precinct F211
Local Accident Number 7086625
SP2F1260JG99

IMPORTANT: If you are the officer in charge, complete and sign this form, and attach it to the MV-104A or MV-104AN.

Accident Date	Accident Time	County
8 / 19 / 2016 Month Day Year	In Military Time 14:45	ORANGE

NAMES OF DRIVERS: (Please Print or Type)

*	Last	First	M.I.	State of Veh. Reg.	Plate Number	Driver License State	Driver License Number
VEH 1 <input type="checkbox"/>	SANTOPIETRO	JOSEPH	P	NY	POLICE	NY	[REDACTED]
VEH 2							
VEH 3							
VEH 4							
VEH 5							
VEH 6							

Pursuant to Section 605 of the New York State Vehicle and Traffic Law, the attached Police Accident Report is also the motorist report for vehicle number(s) 1

* Pursuant to Section 605(a)(4) of the Vehicle and Traffic Law, check **only** the box for each police officer operating a police vehicle (as defined by V & T Section 132-a) **during emergency operation** (as defined by V&T Section 114-b) when the accident occurred.

Date 08/26/2016 12:45	Signature of Owner of Police Vehicle/Police Agency Representative <i>T. Scott J. Hall</i>	NCIC# 13502
--------------------------	--	----------------

DIGITAL PHOTO RECORD **INSTRUCTIONS:** • Complete a separate form for each investigation
• Print or type all entries

STATION SP Middletown	CASE NUMBER 7086625	FIU LEAD NUMBER	INCIDENT DATE 8/19/16	PHOTO DATE 8/19/16	TIME BEGAN 3:25 PM COMPLETED 3:36 PM	
--------------------------	------------------------	-----------------	--------------------------	-----------------------	---	--

INVESTIGATING MEMBER T/Sgt. William J. Meyers	PHOTOGRAPHER'S NAME Sgt. Mark A. Prestigiacomo
--	---

CASE TYPE Division Vehicle - PDAA	COMPLAINANT - DEFENDANT - OPERATOR - DECEASED Trooper Joseph P. Santopietro
--------------------------------------	--

COUNTY Orange	ADDRESS OR LOCATION Interstate 84 W/B Exit 3E T/Wawayanda
------------------	--

GENERAL DESCRIPTION OF SCENE / ITEM(S) F106 (2014 Dodge Charger)/Accident Scene	ACTION REQUESTED <input type="checkbox"/> Burn To CD/DVD <input checked="" type="checkbox"/> Print 2 <input checked="" type="checkbox"/> Retain
--	--

CAMERA Kodak	IMAGE TYPE OR FILE FORMAT <input checked="" type="checkbox"/> JPEG <input type="checkbox"/> TIF <input type="checkbox"/> Raw	PAGE # 1 OF 1	DATE SUBMITTED TO FIU 8/19/16	MANNER SUBMITTED: (Check one) <input checked="" type="checkbox"/> CD/DVD <input type="checkbox"/> E-MAIL <input type="checkbox"/> Other
-----------------	---	---------------	----------------------------------	--

IMAGE#	CAMERA PHOTO ID#	DESCRIPTION:	IMAGE#	CAMERA PHOTO ID#	DESCRIPTION:
1	2743	Front F106	39		
2	2744	Front F106	40		
3	2745	Front F106	41		
4	2746	Passenger Side F106	42		
5	2747	Rear F106	43		
6	2748	Rear F106	44		
7	2749	Rear F106	45		
8	2750	Driver Side F106	46		
9	2751	Scene facing west	47		
10	2752	Scene facing west	48		
11	2753	Scene facing west	49		
12	2754	Scene facing west	50		
13	2755	Scene facing east	51		
14			52		
15			53		
16			54		
17			55		
18			56		
19			57		
20			58		
21			59		
22			60		
23			61		
24			62		
25			63		
26			64		
27			65		
28			66		
29			67		
30			68		
31			69		
32			70		
33			71		
34			72		
35			73		
36			74		
37			75		
38			76		



100_2743.JPG
8/19/2016 3:25:25 PM



100_2744.JPG
8/19/2016 3:25:42 PM



100_2745.JPG
8/19/2016 3:26:00 PM



100_2746.JPG
8/19/2016 3:26:17 PM



100_2747.JPG
8/19/2016 3:26:36 PM



100_2748.JPG
8/19/2016 3:27:13 PM



100_2749.JPG
8/19/2016 3:27:30 PM



100_2750.JPG
8/19/2016 3:27:47 PM



100_2751.JPG
8/19/2016 3:34:45 PM



100_2752.JPG
8/19/2016 3:35:40 PM



100_2753.JPG
8/19/2016 3:35:57 PM



100_2754.JPG
8/19/2016 3:36:13 PM



100_2755.JPG
8/19/2016 3:36:29 PM

T & C AUTO BODY, INC.
 770 Rt 17 M, Po Box 2164, MIDDLETOWN, NY
 10940
 Phone: (845) 343-3443
 FAX: (845) 342-4330

Workfile ID: 8bee3422
 State ID: 7000221

Preliminary Estimate

Customer: New York State Police #140554

Job Number:

Written By: Chris Clark, IA-941114

Insured: New York State Police
 #140554

Policy #:

Claim #:

Type of Loss:

Date of Loss:

Days to Repair: 0

Point of Impact:

Owner:

New York State Police #140554
 55 Crystal Run Rd.
 Middletown, NY 10941
 (845) 344-5300 Business

Inspection Location:

T & C AUTO BODY, INC.
 770 Rt 17 M
 Po Box 2164
 MIDDLETOWN, NY 10940
 Repair Facility
 (845) 343-3443 Business

Insurance Company:

VEHICLE

2014 DODG CHARGER POLICE AWD 4D SED 8-5.7L-FI Blue

VIN: 2C3CDXKT1EH356790

Interior Color:

Mileage In: 25,532

Vehicle Out:

License: F106

Exterior Color: Blue

Mileage Out:

State: NY

Production Date:

Condition: Good

Job #:

TRANSMISSION

Automatic Transmission
 4 Wheel Drive

POWER

Power Steering
 Power Brakes
 Power Windows
 Power Locks
 Power Mirrors
 Power Driver Seat

DECOR

Dual Mirrors

Tinted Glass

Overhead Console

CONVENIENCE

Air Conditioning
 Intermittent Wipers
 Tilt Wheel
 Cruise Control
 Rear Defogger
 Keyless Entry
 Message Center
 Steering Wheel Touch Controls

RADIO

AM Radio

FM Radio

Stereo

Search/Seek

Auxiliary Audio Connection

SAFETY

Drivers Side Air Bag
 Passenger Air Bag
 Anti-Lock Brakes (4)
 4 Wheel Disc Brakes
 Front Side Impact Air Bags
 Head/Curtain Air Bags

SEATS

Cloth Seats
 Bucket Seats

WHEELS

Styled Steel Wheels

PAINT

Clear Coat Paint

OTHER

Traction Control
 Stability Control
 Power Trunk/Gate Release

Preliminary Estimate

Customer: New York State Police #140554

Job Number:

2014 DODG CHARGER POLICE AWD 4D SED 8-5.7L-FI Blue

Line	Oper	Description	Part Number	Qty	Extended Price \$	Labor	Paint
1 FRONT BUMPER							
2	#	Add for push bar		1		1.0	
3	#	R&I License plate				0.2	
4		O/H front bumper				2.6	
5	Repl	Bumper cover w/auto cruise	68092597AA	1	345.00	Incl.	3.2
6		Add for Clear Coat					1.3
7	Repl	RT Bezel w/auto cruise	5182372AA	1	24.25	Incl.	
8	Repl	LT Bezel w/auto cruise	68092614AA	1	24.20	Incl.	
9 FRONT LAMPS							
10	Repl	RT Headlamp assy w/o HID	57010410AE	1	279.00	0.3	
11		Ajm headlamps				0.5	
12 RADIATOR SUPPORT							
13	Repl	Crossmember	5065240AG	1	197.00	0.5	0.8
14	Repl	Front shield 3.6 & 5.7 liter	57010338AD	1	123.00	Incl.	
15	Repl	Splash shield w/AWD	4806075AB	1	82.20	0.2	
16	Repl	Front shield pin	6506132AA	6	28.20		
17 COOLING							
18	Repl	Radiator	68050126AB	1	364.00 m	2.3	
19		Deduct for Overlap				-0.5	
20	Repl	Lower seal	68050130AB	1	54.60		
21	**	Repl A/M Coolant		1	36.95		
22	Repl	Fan assy	68050129AA	1	270.00 m	Incl.	
23 AIR CONDITIONER & HEATER							
24	Repl	Condenser assy	68085784AA	1	542.00 m	1.5	
25		AC Service evacuate & recharge				m 1.4	
26		AC Service refrigerant recovery				m 0.4	
27		Deduct for Overlap				-1.0	
28	**	Repl A/M R134 Freon/PAG 150 oil		1	36.95		
29	#	Repl Transmission fluid		1	12.50		
30 HOOD							
31	*	Rpr Hood w/o scoop (ALU)				2.0	3.0
32		Add for Clear Coat					1.2
33 FRONT SUSPENSION							
34	Repl	Wheel alignment align four wheels		1		m 1.7	
35 FENDER							
36	Repl	RT Fender	55113584AB	1	264.00	1.6	2.0
37		Overlap Major Adj. Panel					-0.4
38		Add for Clear Coat					0.3
39		Add for Edging					0.5
40		Add for Clear Coat					0.1
41	R&I	RT Fender liner				Incl.	
42	R&I	LT Fender liner				0.3	

Preliminary Estimate

Customer: New York State Police #140554

Job Number:

2014 DODG CHARGER POLICE AWD 4D SED 8-5.7L-FI Blue

43	Repl	RT Fender liner retainer	6506132AA	5	23.50		
44	Repl	LT Fender liner retainer	6506132AA	5	23.50		
45	WINDSHIELD						
46	R&I	RT Washer nozzle				0.2	
47	R&I	LT Washer nozzle				0.2	
48	FRONT DOOR						
49	Blnd	RT Door shell (HSS)					1.1
50	R&I	RT Applique				0.2	
51	*	R&I RT Power mirror				0.5	
52	*	R&I RT Handle, outside				0.4	
53		R&I RT R&I trim panel				0.5	
54	#	Rpr RT Frt door decals				1.0	
55	REAR LAMPS						
56		O/H rear bumper				2.0	
57	Repl	RT Side marker lamp	68039504AA	1	28.25	Incl.	
58	Repl	LT Side marker lamp	68039505AA	1	28.10	Incl.	
59	**	Repl A/M RT Marker lamp bulb	L0000168	1	2.35	Incl.	
60	**	Repl A/M LT Marker lamp bulb	L0000168	1	2.35	Incl.	
61	REAR BODY & FLOOR						
62	*	Rpr Rear body panel				1.5	1.2
63		Overlap Major Non-Adj. Panel					-0.2
64		Add for Clear Coat					0.2
65	REAR BUMPER						
66	Repl	Bumper cover w/rev sensor	68092609AB	1	354.00	Incl.	3.2
67		Add for Clear Coat					1.3
68		Add for reverse sens				0.3	
69	#	Add for auxillary lights		1		0.6	
70	Repl	Rear valance	68092615AA	1	217.00	Incl.	
71	*	Repl Reverse sensor	1EW63TZZAA	4	436.00	0.4	1.2
72		Add for Clear Coat					0.2
73	Repl	RT Side support	57010288AD	1	15.85	0.1	
74	Repl	LT Side support	57010289AD	1	15.45	0.1	
75	Repl	RT Side bracket	5182268AD	1	18.95	0.2	
76	Repl	LT Side bracket	5182269AD	1	18.95	0.2	
77	Repl	RT Outer support	57010614AF	1	6.70	0.1	
78	Repl	LT Outer support	57010615AF	1	6.70	0.1	
79	Repl	Retainer ring	4806474AA	4	46.40		
80	Repl	Energy absorber	57010467AB	1	48.95	Incl.	
81	Repl	Wire harness	68092616AA	1	329.00		
82	#	Repl Rear bumper heatshields		1	79.89	0.2	
83	#	R&I License plate				0.2	
84	#	Rpr Clean mud/debris from bottom of vehicle				3.0	
85	#	Repl Install rear bumper and RT/Frt decals		1		1.5	

Preliminary Estimate

Customer: New York State Police #140554

Job Number:

2014 DODG CHARGER POLICE AWD 4D SED 8-5.7L-FI Blue

86	#	Rpr	De Nib & Polish			1.0	
87	#	Rpr	Disable SRS			0.5	
88	#	Rpr	Tint Color				0.5
89	#	Repl	Corrosion Protection	1			0.5
90	#	Repl	Flex additive	2	25.00		
91	#		Car Cover	1	8.00	0.3	
92	#		Hazardous Waste	1	3.50		
93	#	Repl	Paint and materials as per Mitchell RMC	1	749.42		
SUBTOTALS					5,171.66	30.3	21.2

NOTES

Estimate Notes:

8/26/16 @ 8:15 faxed to Donny

ESTIMATE TOTALS

Category	Basis	Rate	Cost \$
Parts			5,171.66
Body Labor	30.3 hrs @	\$ 52.00 /hr	1,575.60
Paint Labor	21.2 hrs @	\$ 52.00 /hr	1,102.40
Subtotal			7,849.66
Grand Total			7,849.66
Deductible			0.00
CUSTOMER PAY			0.00
INSURANCE PAY			7,849.66

ANY PERSON WHO KNOWINGLY AND WITH INTENT TO DEFRAUD ANY INSURANCE COMPANY OR OTHER PERSON FILES AN APPLICATION FOR COMMERCIAL INSURANCE OR A STATEMENT OF CLAIM FOR ANY COMMERCIAL OR PERSONAL INSURANCE BENEFITS CONTAINING ANY MATERIALLY FALSE INFORMATION. OR CONCEALS FOR THE PURPOSE OF MISLEADING, INFORMATION CONCERNING ANY FACT MATERIAL THERETO, AND ANY PERSON WHO, IN CONNECTION WITH SUCH APPLICATION OR CLAIM, KNOWINGLY MAKES OR KNOWINGLY ASSISTS, ABETS, SOLICITS OR CONSPIRES WITH ANOTHER TO MAKE A FALSE REPORT OF THE THEFT, DESTRUCTION, DAMAGE OR CONVERSION OF ANY MOTOR VEHICLE TO A LAW ENFORCEMENT AGENCY, THE DEPARTMENT OF MOTOR VEHICLES OR AN INSURANCE COMPANY, COMMITS A FRAUDULENT INSURANCE ACT, WHICH IS A CRIME, AND SHALL ALSO BE SUBJECT TO A CIVIL PENALTY NOT TO EXCEED FIVE THOUSAND DOLLARS AND THE VALUE OF THE SUBJECT MOTOR VEHICLE OR STATED CLAIM FOR EACH VIOLATION.

You are entitled to the return of all replaced parts, except warranty and exchange parts, but you must ask for them in writing before any work is done. If you authorize work by phone, the shop must keep any replaced parts, and make them available when you pick up the vehicle.